

Respond to the needs, "safe and comfortable"

SHOWA

Vibration-Transmitter

VIBRO-CONVERTER

MODEL

2502

For vibration monitoring and control
with simple and reliable.

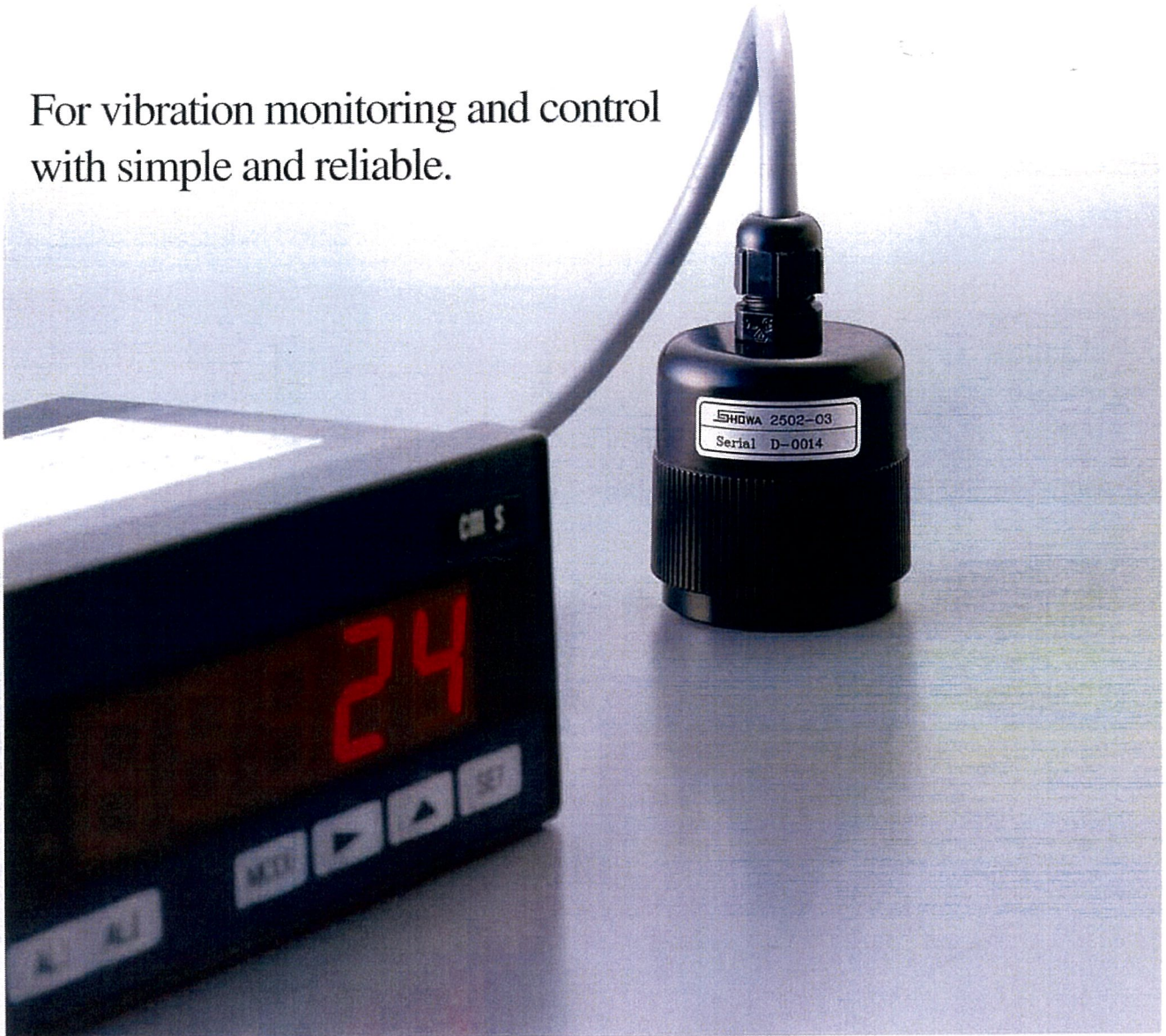

■ FEATURES

- Three types; measurements for displacement, velocity and acceleration.
- As output is 4 to 20 mA, it is possible to connect to recorder, indicator and sequential circuit directly.
- Small size! light weight! low price!
All in one type for sensor, amplifier and transmitter.
- It is only double lines type, joined together for both lines, power supply and signal.

■ APPLICATIONS

- For simple vibration monitoring system with low cost.
- As for assembling into the electric motors, blowers, pumps and the other various rotating machines.
- As the vibration sensor in the automatic inspection system.
- As for the simple type vibration meter.
- For trend recording of vibration level.

Vibration Transmitter VIBRO-CONVERTER MODEL 2502

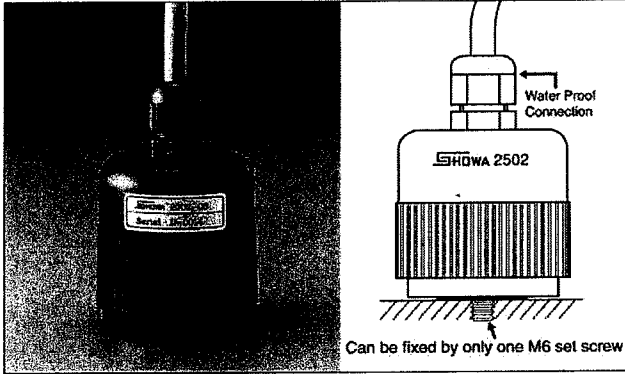

Specifications

Model	2502-03	2502-02	2502-01
Type	Displacement	Velocity	Acceleration
Full scale range	200 μ mP-P	50mm/s RMS	100m/s ² Peak
Measuring range	1%~110% of Full scale		
Output current	4 to 20mA		
Frequency range	10~500Hz	10~1000Hz	5~1000Hz
Linearity	Within 1%		
Accuracy	Within 5% (80Hz, 1/2 Full scale, 20°C)		
Transverse sensitivity	Less than 5%		
Driving voltage	9~28V DC		
Warming up time	10sec. approx		
Ambient temperature	-20°C to +60°C		
Protection	IP64		
Vibration limit	200m/s ² for continuous 1000m/s ² for shock		
Resonant frequency	5kHz approx		
Withstand voltage	AC1500V 1minute		
Output cable	3m pig tale		
Dimensions	ϕ 45×H45mm		
Weight	105g without cable		
Accessories	Setscrew M6 $l=10$		
Option	Digital monitor 2590 Mounting base		

Basic Wiring Circuit

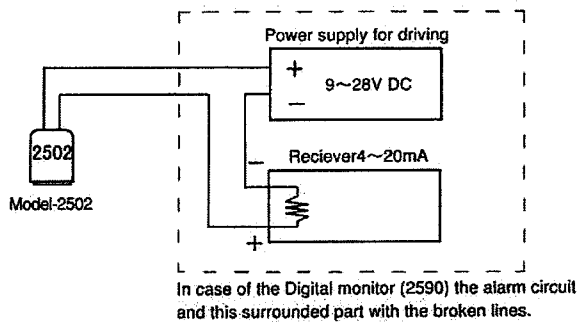

Examples for the indicators and meters to be possible to connect

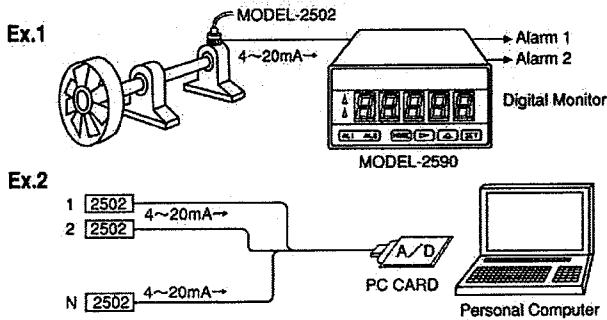

Drawing for the External View

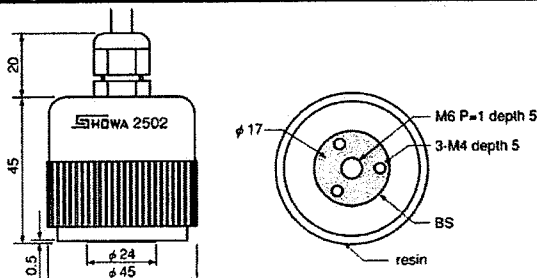

SHOWA Respond to the needs. "safe and comfortable"

SHOWA SOKKI CORPORATION

Head Office : 1-5-9, Kandaizumi-cho, Chiyoda-ku, Tokyo, 101-0024
Tel. 03-3866-3210 (main) Fax. 03-3866-3060
Osaka Branch : Hiranomachi Grand Building 6F EAST,
1-7-14, Hiranomachi, Chuo-ku, Osaka, 541-0046
Tel. 06-6205-5070 (main) Fax. 06-6125-5111
Factory : 3-16-2, Sennin-cho, Hachioji-shi, Tokyo, 193-0835
Tel. 042-664-3232 (main) Fax. 042-664-3276
<https://www.showasokki.co.jp/> mail : eigyo@showasokki.co.jp

Agent: