

Vibro-Switch Model-1500B

Detects unusually great vibrations and gives an alarm signal. Sensor, alarm setting and alarm contact are entirely united in one body for ease of operation.



- Compact design, low price and accurate vibration monitoring at 2 upper limits.
- Vibration modes for acceleration, velocity and displacement are selectable with internal switch.
- Drip-proof aluminum housing connectable with cable gland.
- Alarm level setting at a step of 1% from 1 to 99% with internal digital switch
- Two different alarming steps, one for self-holding operation and the other for automatic resetting operation are provided.
- Alarm delay of up to 60 seconds can be set to prevent malfunction.
- Low power consumption of 12mA(Typ) at 24V DC.
- Usable for monitoring vibrations in motors, fans, piping, etc.

Vibro-Switch

Model-1500B

SPECIFICATIONS

Alarm setting range: (Select 1,2 or 3.)	① Acceleration: 1~99m/s ² (p) ② Velocity: 1~99mm/s(p) ③ Displacement: 0.01~0.99mm(P-P)
Frequency characteristics: (+5%, -10%)	Acceleration: 5~500Hz Velocity: 10~500Hz Displacement: 10~500Hz
Accuracy:	Within 5% (25°C, 80Hz, 10m/s ² measurement of sinusoidal wave)
Linearity:	Within 1% of full scale
Driving power supply:	DC24V±0.5V, 12mA(Typ), 20mA(max)
Relay operation:	Delay 0 to 60 sec variable Self-holding operation and automatic resetting operation, make contact by MOSFET. (Resetting by turning off driving power supply) Contact rating AC/DC 125V, 0.5A
Housing construction:	Material Aluminium(with neoprene packing) Protection IP-64
Vibration resistance:	10m/s ² for vibration, 100m/s ² for shock
Dielectric strength:	1500V AC between relay contact and housing for 1 minute 1500V AC between relay contact and power supply (24V) for 1 minute Power line is connected to housing at 0.1 μF
Applicable electric wire:	0.2~2.5mm ² (AWG24~16)
Applicable cable:	Outside diameter of cable : φ11~13mm
Operating temperature:	-10°C~+70°C

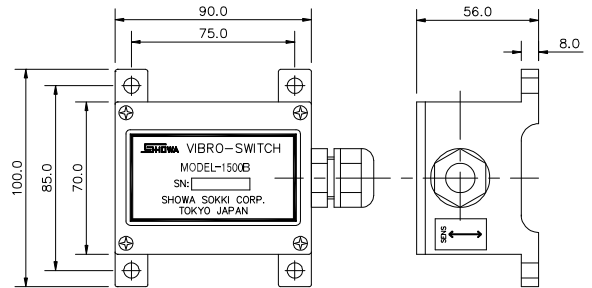

Example for built-in a machine

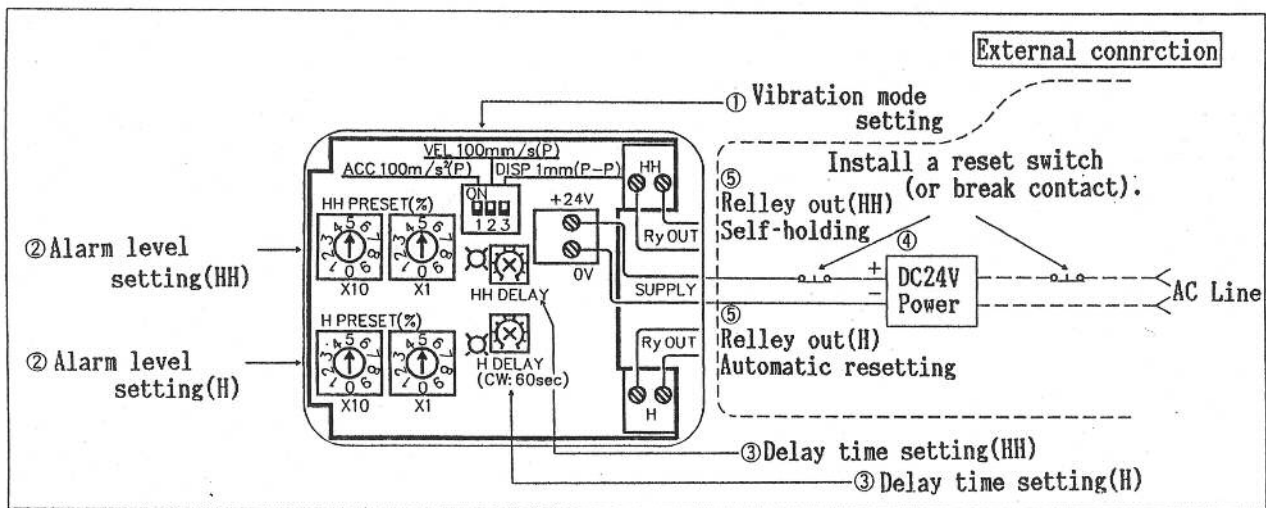
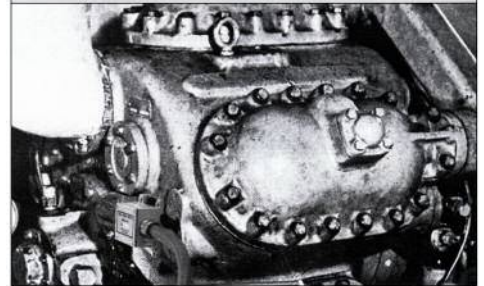

SHOWA Respond to the needs; "safe and comfortable"

SHOWA SOKKI CORPORATION

Head Office :1-5-9,Kandaizumi-cho,Chiyoda-ku,Tokyo,101-0024
Tel.03-3866-3210(main)Fax.03-3866-3060
Osaka Branch :Hiranomachi Grand Building 6F EAST,
1-7-14,Hiranomachi,Chuo-ku,Osaka, 541-0046
Tel.06-6205-5070(main)Fax.06-6125-5111
Factory :3-16-2,Sennin-cho,Hachioji-shi,tokyo,193-0835
Tel.042-664-3232(main)Fax.042-664-3276
<https://www.showasokki.co.jp/> mail : eigy@showasokki.co.jp

Agent: